











We are pleased to offer several options to help you in your design process. Secondary services such as splitting in half, quarter notching, electrical outlet notching, and hanger bolt installation are available on the majority of our columns, legs and bun feet. Additional charges apply.

<p>QUARTER CUT</p>  <p>01QUARTERNOTCH</p> <p>Quarter notching creates a single quartered piece and a single 3/4 piece. Both pieces are included in purchase.</p>	<p>SPLIT</p>  <p>01SPLITCOLUMN</p> <p>Split column in half. 1/8" of thickness may be lost due to saw kerf. Both halves are included in purchase.</p>	<p>ANGLE CUT</p>  <p>01ANGLECUT</p> <p>Product is cut at an angle from corner to corner, full length only. Both pieces are included in purchase.</p>	<p>STOP NOTCH</p>  <p>01STOPNOTCH</p> <p>Stop notch a column. Let us know how far down you would like notched.</p>	<p>ELECTRICAL BORE</p>  <p>01ELECBORE</p> <p>A 1/2" hole through the entire length of the column.</p>
---	---	---	---	--

<p>SPLIT BUN FOOT</p>  <p>01SPLITFEET</p> <p>Split bun foot in half. Both pieces are included in purchase.</p>	<p>INSERT</p>  <p>01INSERT</p> <p>5/16" EZ Lock Insert for hardwood installed in one end.</p>	<p>SCREW</p>  <p>01DOWELSCREW</p> <p>5/16-18 wood dowel screw installed in one end. Dowel screw installed to protrude 1".</p>	<p>HANGER BOLT</p>  <p>01HANGERBOLT</p> <p>5/16-18 hanger bolt installed in one end. Hanger bolt installed to protrude 1/2".</p>	<p>BOX ROUTE</p>  <p>01BXRROUTE</p> <p>Add an electrical box to your column.</p>
---	--	--	--	---

*Please note - not all items can be cut in all the formats above, nor can all columns receive an Electrical Box Notch. Please review the product on our website to determine which operations are available or contact customer service at 1-800-328-5858 for more information.
www.brownwoodinc.com/dod

All custom cut products are non-returnable.

CHAMFER

Customize our stock 3", 4", 5" or 6" square columns. Priced per corner. Set-up charges may apply for all custom cuts.

Fax this form to 800-884-0423 or fill out our online PDF and email it to custom@brownwoodinc.com.

Company Name: _____	Phone: _____
Contact Name: _____	Email: _____
Date: _____	PO #: _____

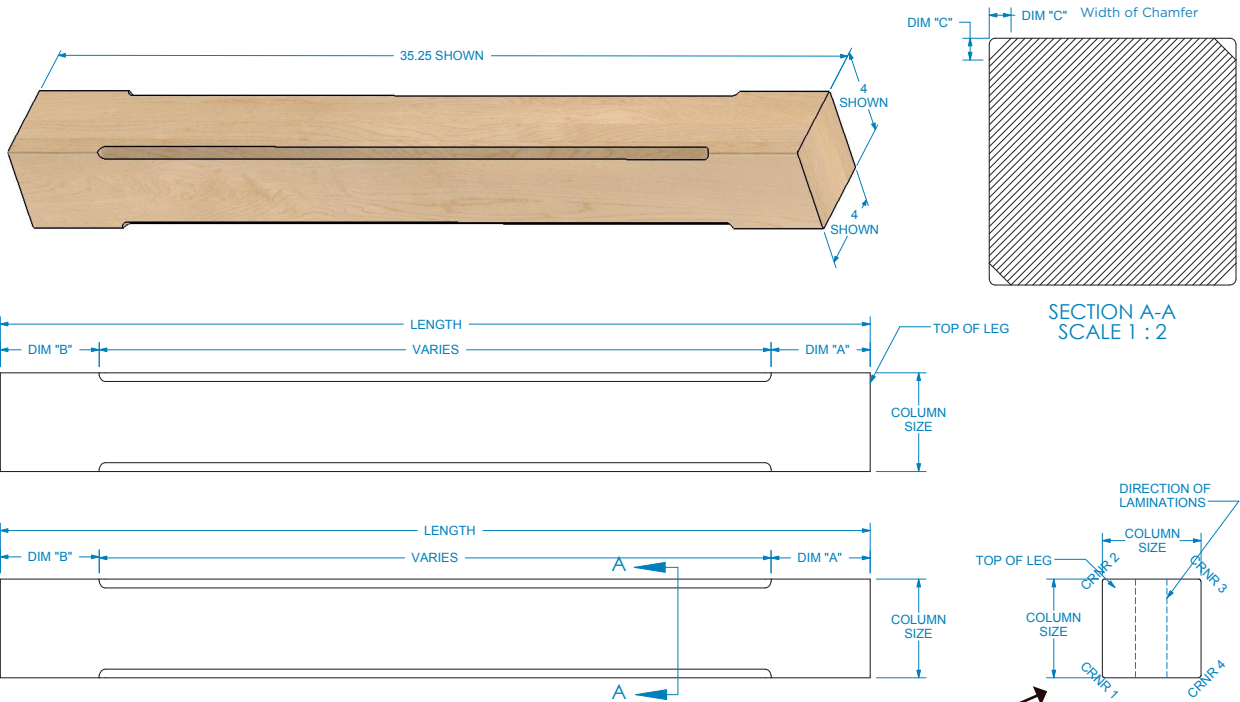

2) Column Size:

- 3"
- 4"
- 5"
- 6"
- Other: _____

3) Length:

- 35.25"
- 42.25"
- Other: _____

4) Detail on Corners:

- Use the diagram in order to choose which corners you would like the detail on.
- Corner 1
 - Corner 2
 - Corner 3
 - Corner 4

5) DIM "A":

- 2"
- 3"
- 4"
- 5"
- Other: _____

6) DIM "B":

- 3"
- 4"
- 5"
- 6"
- Other: _____

7) DIM "C":

Width of Chamfer

- .25"
- .375"
- .5"
- Other: _____

8) Species:

- | | | | |
|----------------------------------|---|------------------------------------|-------------------------------------|
| <input type="checkbox"/> Red Oak | <input type="checkbox"/> Alder | <input type="checkbox"/> Cherry | <input type="checkbox"/> Hard Maple |
| <input type="checkbox"/> Hickory | <input type="checkbox"/> Qtr Sawn Red Oak | <input type="checkbox"/> White Oak | <input type="checkbox"/> Walnut |
- Other: _____

8) Special Notes: _____

SINGLE SHAKER

Customize our stock 3", 4", 5" or 6" square columns. Priced per side. Set-up charges may apply for all custom cuts.

Fax this form to 800-884-0423 or fill out our online PDF and email it to custom@brownwoodinc.com.

Company Name: _____ Phone: _____
 Contact Name: _____ Email: _____
 Date: _____ PO #: _____

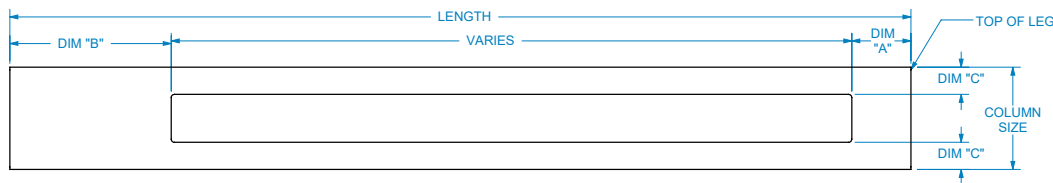
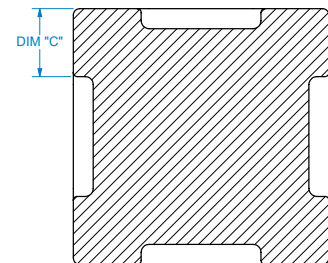

SECTION A-A
SCALE 1 : 2

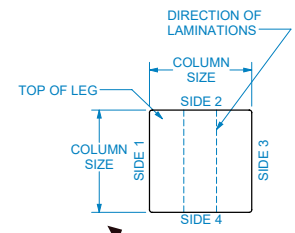
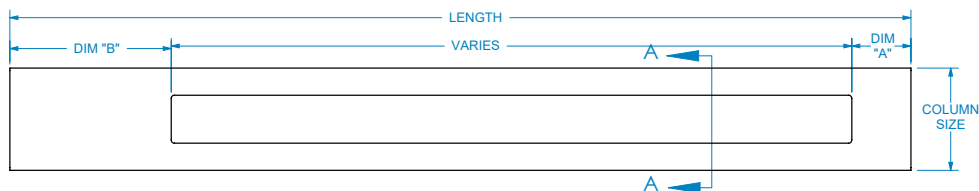

1) Column Size:

- 3"
- 4"
- 5"
- 6"
- Other: _____

2) Length:

- 35.25"
- 42.25"
- Other: _____

3) Detail on Sides:

Use the diagram in order to choose which sides you would like the detail on.

- Side 1
- Side 2
- Side 3
- Side 4

5) DIM "A":

- 2"
- 3"
- 4"
- 5"
- Other: _____

6) DIM "B":

- 3"
- 4"
- 5"
- 6"
- Other: _____

7) DIM "C":

- .25"
- .75"
- 1"
- Other: _____

8) Species:

- Red Oak
- Alder
- Cherry
- Hard Maple
- Hickory
- Qtr Sawn Red Oak
- White Oak
- Walnut
- Other: _____

8) Special Notes: _____

DOUBLE SHAKER

Customize our stock 3", 4", 5" or 6" square columns. Priced per side. Set-up charges may apply for all custom cuts.

Fax this form to 800-884-0423 or fill out our online PDF and email it to custom@brownwoodinc.com.

Company Name: _____ Phone: _____
 Contact Name: _____ Email: _____
 Date: _____ PO #: _____

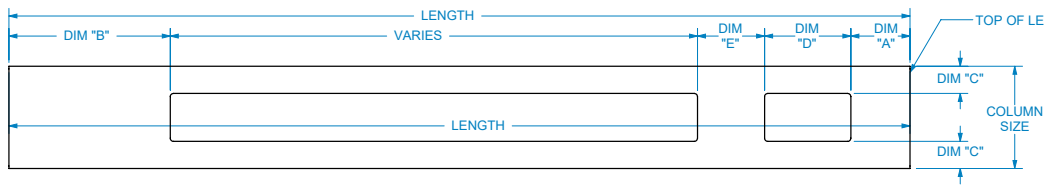
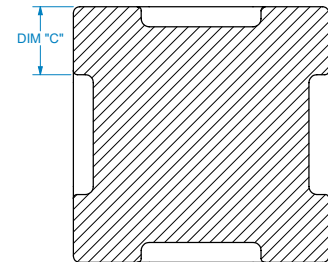

SECTION A-A
SCALE 1 : 2

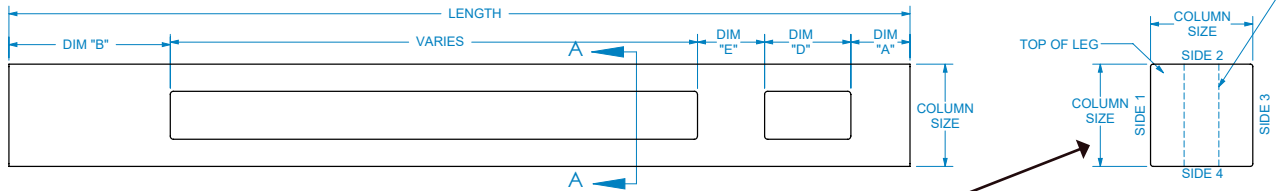

2) Column Size:

3"
 4"
 5"
 6"
 Other: _____

3) Length:

35.25"
 42.25"
 Other: _____

4) Detail on Sides:

Use the diagram in order to choose which sides you would like the detail on.

Side 1
 Side 2
 Side 3
 Side 4

5) DIM "A":

2"
 3"
 4"
 5"
 Other: _____

6) DIM "B":

3"
 4"
 5"
 6"
 Other: _____

7) DIM "C":

.5"
 .75"
 Other: _____

8) DIM "D":

3"
 4"
 5"
 6"
 Other: _____

9) DIM "E":

2"
 3"
 4"
 5"
 Other: _____

8) Species:

Red Oak Alder Cherry Hard Maple Hickory Qtr Sawn Red Oak White Oak Walnut Other: _____

10) Special Notes: _____

Stock X-Panels are available.
Please see page 39 of our
catalog or visit our website for
more information.

CUSTOM X-PANEL QUOTE REQUEST

Fax this form to 800-884-0423 or fill out our online PDF and email it to custom@brownwoodinc.com.

Company Name: _____ Phone: _____
 Contact Name: _____ Email: _____
 Date: _____

1) Choose Your Style

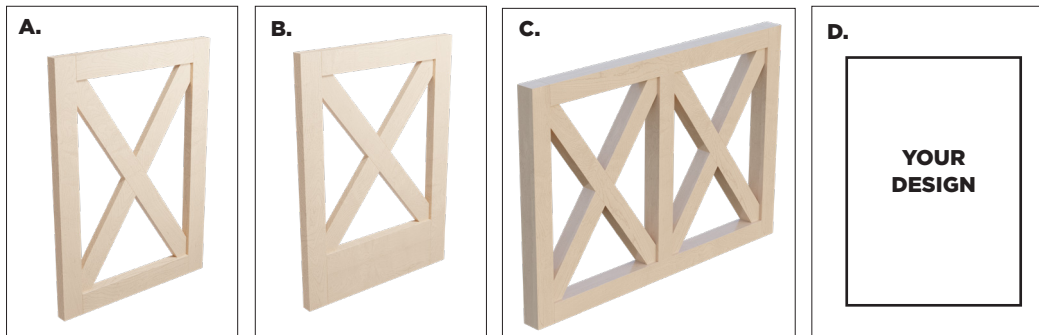

- Standard Frame**
• 3" Rails
- Extended Frame**
• 3" Rails
• 7" Bottom Rail
- Double Frame**
• 3" Rails
- Custom Style**
• Rail Size: _____

2) Indicate Thickness: **3) Overall Dimensions:** **4) Add Back Panel** **5) Quantity:** _____

- 1.5"
- 3"
- Other: _____

Width: _____
 Height: _____



6) X - Centered/Recessed/Flush

- X - Centered - recessed both faces
- X - Recessed face, flush other face
- X - Flush both faces

7) Species

- 
 Red Oak
- 
 Alder
- 
 Cherry
- 
 Hard Maple
- 
 Hickory
- 
 Qtr Sawn Red Oak
- 
 White Oak
- 
 Walnut
- OTHER

CUSTOM .25" THICK HDF LASER CUT END PANELS QUOTE REQUEST

Made of high density fiberboard and ready-to-paint.
 Laser cutting allows for tighter cuts and intricate designs.

Fax this form to 800-884-0423 or fill out our online PDF and email it to custom@brownwoodinc.com.

Company Name: _____ Phone: _____
 Contact Name: _____ Email: _____
 Date: _____

1) Choose Your Style - Ready to paint .25" thick HDF

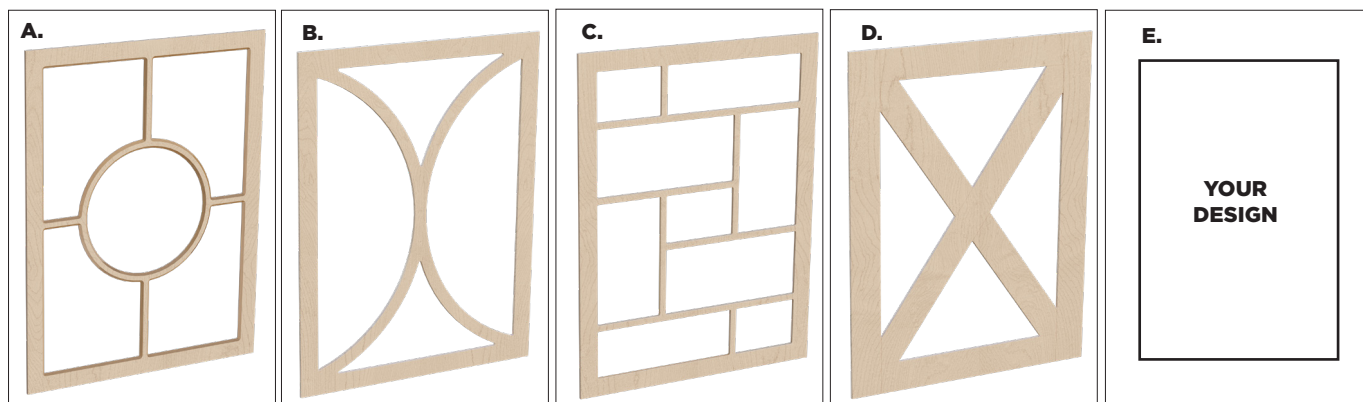

- Panel A Panel B Panel C Panel X Custom Style

Email your design to custom@brownwoodinc.com.

2) Overall Dimensions

Width: _____

Height: _____

3) Quantity

of Panels: _____

Advantages of HDF:

- No graining which results in a better and smoother finish for painting
- No cracking. HDF will not crack, even under severe fluctuations in temperature and humidity, completely maintaining the integrity of the finish
- No warping. HDF does not experience movement from expansion and contraction like traditional hardwoods.

CUSTOM .5" THICK HARDWOOD CNC ROUTED END PANEL QUOTE REQUEST

Crafted from North American Hardwoods.

Fax this form to 800-884-0423 or fill out our online PDF and email it to custom@brownwoodinc.com.

Company Name: _____ Phone: _____
 Contact Name: _____ Email: _____
 Date: _____

1) Choose Your Style - .5" thick hardwood, ready to stain

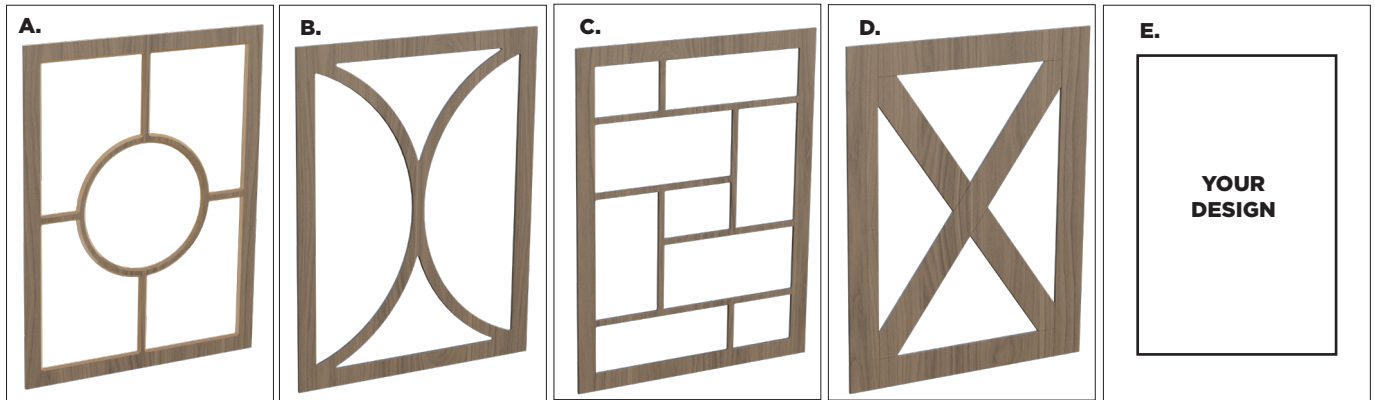

- Panel A Panel B Panel C Panel X Custom Style

2) Overall Dimensions

Width: _____
 Height: _____

Advantages of Hardwood:

- Features a beautiful natural look to it with grain patterns.
- Sustainable.
- Can be stained.

3) Quantity

of Panels: _____

4) Species



CUT-TO-SIZE DECORATIVE GRILLE QUOTE REQUEST & ORDER FORM

Hand-woven and electroplated grilles. Made in America.
See our website for full details: www.brownwoodinc.com/dod

Company Name: _____ Phone: _____
 Contact Name: _____ Email: _____
 Date: _____ PO #: _____
 Ship To Address: _____

Blind ship.

1) Choose Your Style -

Please duplicate and fill out this form for each style of grille being ordered.

2) Add-On: Installation Gasket

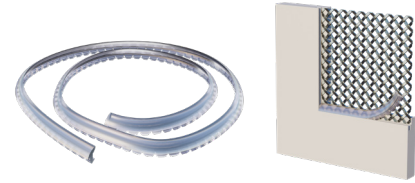
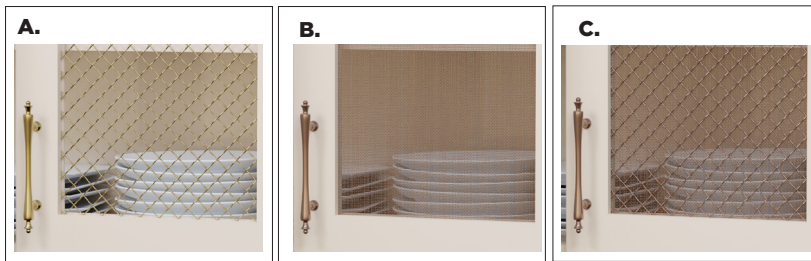

Grille Only Mesh Only Grille & Mesh

3) Grille Choice*

315C
 332P
 1214F
 1220T
Only available in AB, AP and WR
 RE25
 11614P
 CG10
 MD11
 286S
 Custom Style. Kent #: _____

4) Grille Finish

AB Antique Brass
 AP Antique Pewter
 SB Satin Brass
 SN Satin Nickel
 SS Stainless Look
 WR Flat Black
 CP Copper

Custom Finish: _____

5) Mesh Choice

SB Satin Brass
 SN Satin Nickel
 WR Flat Black
 CP Copper

Custom Finish: _____

6) Dimensions of Interior Door Opening & Quantity

A) _____ #: _____ E) _____ #: _____
 B) _____ #: _____ F) _____ #: _____
 C) _____ #: _____ G) _____ #: _____
 D) _____ #: _____ H) _____ #: _____

7) Please send scrap material.

* Due to the cutting of the grille, there is a tolerance of 1/8".
 * Grille is not welded and wires will separate if not handled with extreme care.

Fax this form to 800-884-0423 or fill out our online PDF and email it to custom@brownwoodinc.com.



CUSTOM BISTRO SHELVING CONFIGURATIONS



Style A: Wall to Floor

Style B: Ceiling to Floor

Style C: Wall to Counter

Style D: Ceiling to Wall

Style E: Ceiling to Counter

Style F: Wall to Wall

Style G: Ceiling to Ceiling

- Custom bistro shelving built to your specifications
- Seven configurations
- Three styles: Traditional, Modern Round and Modern Square
- Eleven finishes available

CUSTOM MODERN ROUND BISTRO SHELF QUOTE REQUEST

Fax this form to 800-884-0423 or email it to custom@brownwoodinc.com.

Fully assembled and ready to install or components only.

All shelf sets include easy-to-follow installation instructions. We highly recommend installing into studs to provide the greatest support. Steel supports sold separately. Does not include shelves.

Company Name: _____ Phone: _____
 Contact Name: _____ Email: _____
 Date: _____

1) Configuration (A-G): _____

See Configuration Page for options.

2) # of Shelves: _____

3) # of Vertical Uprights: _____

*We recommend no more than 36" between vertical uprights

5) # of Steel Arm Supports: _____

6) # of Steel Ceiling Supports: _____

7) Overall Height: _____

8) Shelf Depth*: _____

*We do not provide shelves.

9) Overall Depth (calculate below): _____

Calculate Overall Depth:

Shelf Depth	Collar/ Joint	Overall Depth
For 1.5" Tubing: _____	+ 2.875" =	_____

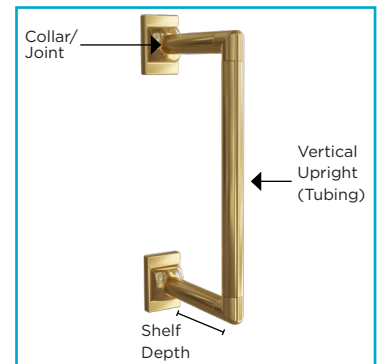

10) Choose Finish:

											OTHER
<input type="checkbox"/>	<input type="checkbox"/>	<input type="checkbox"/>	<input type="checkbox"/>	<input type="checkbox"/>	<input type="checkbox"/>	<input type="checkbox"/>	<input type="checkbox"/>	<input type="checkbox"/>	<input type="checkbox"/>	<input type="checkbox"/>	<input type="checkbox"/>
Polished Brass	Lacquered Polished Brass	Satin Brass	Antique Brass	Polished Copper	Satin Copper	Antique Copper	Polished Nickel	Satin Nickel	Oil Rubbed Bronze	Flat Black	

Please note: Polished brass is unlacquered and will tarnish over time. Please check Lacquered Polished Brass if you would like a lacquered polished brass finish that will not tarnish. All other finishes are lacquered.

11) Want to add a decorative flair?

Simply extend the upright length and add a finial or cap to the top or bottom of your uprights.

<input type="checkbox"/>	<input type="checkbox"/>	<input type="checkbox"/>	<input type="checkbox"/>
Flush Finial	Round Finial	Ball Finial	Scroll Finial (1.5" size only)

- Fully Assembled
- Components Only

Email your drawing/layout to custom@brownwoodinc.com.



CUSTOM MODERN SQUARE BISTRO SHELF QUOTE REQUEST

Fax this form to 800-884-0423 or email it to custom@brownwoodinc.com.

Fully assembled and ready to install or components only.

All shelf sets include easy-to-follow installation instructions. We highly recommend installing into studs to provide the greatest support. Steel supports sold separately. Does not include shelves.

Company Name: _____ Phone: _____

Contact Name: _____ Email: _____

Date: _____

1) Configuration (A-G): _____

See Configuration Page for options.

7) Overall Height: _____

2) # of Shelves: _____

8) Shelf Depth*: _____

*We do not provide shelves.

3) # of Vertical Uprights: _____

*We recommend no more than 36" between vertical uprights

9) Overall Depth (calculate below): _____

Calculate Overall Depth:







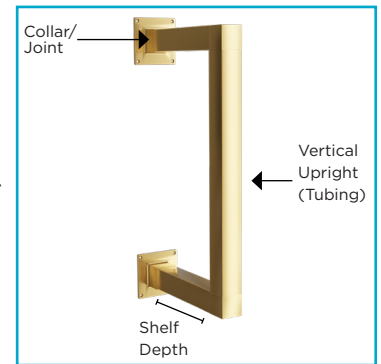



Shelf Width	Collar/ Joint	Overall Depth
_____	_____	_____
_____ + 1.8125" =		_____

5) # of Steel Arm Supports: _____

6) # of Steel Ceiling Supports: _____



10) Choose Finish:

- | | | | | | | | | | | | |
|---|---|---|---|---|---|---|---|--|---|---|--|
|  |  |  |  |  |  |  |  |  |  |  | <div style="border: 1px solid black; padding: 2px; display: inline-block;">OTHER</div> |
| <input type="checkbox"/> | <input type="checkbox"/> | <input type="checkbox"/> | <input type="checkbox"/> | <input type="checkbox"/> | <input type="checkbox"/> | <input type="checkbox"/> | <input type="checkbox"/> | <input type="checkbox"/> | <input type="checkbox"/> | <input type="checkbox"/> | <input type="checkbox"/> _____ |
| Polished Brass | Lacquered Polished Brass | Satin Brass | Antique Brass | Polished Copper | Satin Copper | Antique Copper | Polished Nickel | Satin Nickel | Oil Rubbed Bronze | Flat Black | |

Please note: Polished brass is unlacquered and will tarnish over time. Please check Lacquered Polished Brass if you would like a lacquered polished brass finish that will not tarnish. All other finishes are lacquered.

11) Want to add a decorative flair?

Simply extend the upright length and add a finial or cap to the top or bottom of your uprights.

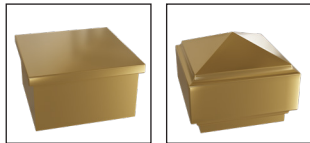

- | | |
|--------------------------|--------------------------|
| <input type="checkbox"/> | <input type="checkbox"/> |
| Flush Square Finial | Flush Pyramid Finial |

- Fully Assembled
 Components Only

Email your drawing/layout to custom@brownwoodinc.com.

